

MANDOLINE SUPER-PRO

Réf. 25000

MODE D'EMPLOI (A CONSERVER) - INSTRUCTIONS (TO BE KEPT)

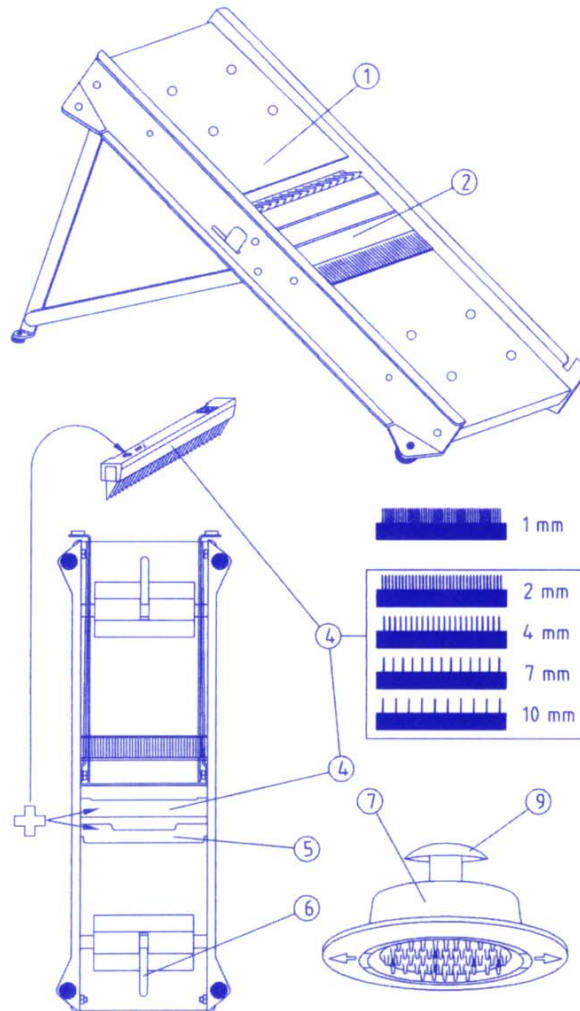

Références - Accessoires - Pièces de rechanges / spare parts

- 10201-3 bloc lames effileur de 1 mm / "comb" cutting blade unit 1 mm
- 10202 bloc lames effileur de 2 mm / "comb" cutting blade unit 2 mm
- 10204 bloc lames effileur de 4 mm / "comb" cutting blade unit 4 mm
- 10207 bloc lames effileur de 7 mm / "comb" cutting blade unit 7 mm
- 10210 bloc lames effileur de 10 mm / "comb" cutting blade unit 10 mm
- 10215 couteau lisse /gaufré / smooth and waffled blade
- 190CL patin anti-dérapant / nonskid pad
- 10201 poussoir de sécurité / guard

DIRECTIONS FOR USE

The Super-pro Mandoline of BRON-COUCKE, thanks to its wonderful blade quality, is able to cut a great variety of shapes, such as, chips, Vichy carrots, souffled potatoes, gratins, vegetable rings, onion rings or slices, matchstick potatoes, "allumettes", julienne, lace-cut potatoes, among others.

The SUPER-PRO MANDOLINE consists of :

- A rigid frame equipped with a reversible stand
- A rigid plate equipped with a smooth blade and a waffled blade
- Two bearing plates adjustable in height with two levers
- 5 removable "comb" cutting blade units with respectively 1, 2, 4, 7 and 10 mm spaces between the multiple blades
- 1 safety guard
- Nonskid pads

This Mandoline is manufactured in stainless steel.

ATTENTION :

Do not attempt to use the SUPER-PRO MANDOLINE until you have studied these instructions carefully. Failure to do so may result in damage to the various cutting edges.

BEFORE FIRST USE :

Before using for the first time, it is recommended that the mandoline be washed in hot water.

INSTRUCTIONS

• MOUNTING OF A "COMB" CUTTING BLADE UNIT :

Insert the "comb" cutting blade unit in the placements provided on the stainless body of the mandoline frame. The "comb" cutting unit should be placed by matching the "cross" sign on the "comb" cutter with the "cross" sign inscribed on the side of the mandoline. If you place the "comb" cutter in the other sense it will not mount on the frame. Fold-back the small holding tongue.

• REMOVAL OF A "COMB" CUTTING BLADE UNIT :

Slide back the small holding tongue to uncover completely the "comb" cutting blade unit. Then you can remove the "comb" cutting unit. Store the "comb" cutting units in the storage box delivered with the mandoline. In this way, the blades will not be damaged.

IN ORDER TO REALIZE THE DESIRED CUTS, PLACE THE STAND OF THE MANDOLINE :

- EITHER TO SLIDE (NEAR THE FLAT BLADE)
- EITHER TO WAFFLE (NEAR THE WAFFLED BLADE)

• HOW TO MAKE STRAIGHT SLICING CUTS :

Make sure that the stand of the mandoline is completely unfolded and in a stable position on the work surface.

Remove the "comb" cutting unit if one is mounted in the mandoline. Adjust the thickness of the cut (which will determine the thickness of the slice that you will cut) with the lever under the bearing plate. Now you can slice your vegetables, always using the guard to hold and push your vegetables towards the blade.

Adjust the height of the waffled blade with the lever under the bearing plate in order to avoid the vegetable be cut on this blade.

• HOW TO CUT INTO STICKS

Install the choosen "comb" cutting blade unit.

Now set the thickness of slice that you want to cut by setting the height of the bearing plate using the lever. Now you can cut the vegetables always using the guard.

The dimensions of the sticks or "bâtonnets" that you cut are generated by, on the one hand the choice of dimension of the "comb" cutting blade unit (1, 2, 4, 7 or 10 mm intervals), and on the other by the height of the slice that you take (adjustment of the bearing plate).

• HOW TO MAKE GAUFRETTES

Remove the "comb" cutting unit if one is mounted in the mandoline. The gaufrettes are cut on the waffled blade. Adjust the thickness of the cut to about 2 mm with the lever. Slice your vegetable using the guard then turn the guard (about 1/4 of a rotation) and slice again and so on. Turn the guard at each slice. Adjust the thickness of the cut to obtain perfect holes in the slices : thicker if the slice falls to bits and thinner if the holes are not properly shaped.

THE GUARD

ALWAYS USE THE GUARD FOR ALL CUTTING OPERATIONS IN ORDER TO AVOID ALL RISK OF INJURY !

The guard is equipped with stainless steel nails so that it can hold properly the vegetable pieces during the cutting operation. There is also a space hollowed out in the guard allowing the guard to hold long vegetables (courgettes for example). In this case, cut with the guard in the direction of the arrows molded into the underside of the guard.

Please note that this guard has a mobile central part which sits proud of the rest of the guard when the stainless steel nails are pushed onto the vegetable to be sliced.

When cutting you should press with a certain pressure on this mobile central part with the palm of the hand in order to push the vegetable down towards the cutter blade during the successive cutting operations.

Again, we repeat, always use the guard for all cutting operations.

MAINTENANCE

The SUPER-PRO MANDOLINE is designed to require only minimal maintenance. From time to time one should sharpen the smooth cutting blade, using a fine hone or stone.

Always store the "comb" cutting units in their box, thus keeping their edges protected while not in use.

For storage, give the Mandoline its own place, often one chooses to hang the Mandoline in the kitchen. The guard can also be hung, if you choose to do so.

CLEANING

Before using for the first time, it is recommended that the Mandoline be washed in hot water. Cleaning is particularly easy. We recommend to remove any "comb" cutting blade unit from the frame (in order to avoid any risk of user injury !) before washing and to wash each part in hot water or hot water and soap separately. Rinse and dry.

Now that you have read these instructions you are ready to try out your SUPER-PRO MANDOLINE. You will see that you can do many many things with this wonderful tool. It will give you the inspiration to try out many new recipes and ideas !

BON APPETIT !!!!