

OPERATING INSTRUCTIONS

See Diagrams (at right) for reference.

ALL MODELS:

Pare, Core and Slice

1. Release groove clamp (B) and draw shaft (C) back, (or wind it back with handle).
2. Press apple firmly, stem-end first, onto 3-prong fork (D). Apple must be on straight, lined up with shaft so paring knife can do a thorough job.
3. Turn handle until paring knife (Z) starts to pare apple. If paring knife doesn't pass around the apple freely, guide it by hand. If paring knife clogs and skips due to a soft apple, clean paring knife to correct.
4. For different sized apples, adjust gap between paring knife and knife holder (E) by loosening screw and sliding paring knife out for deeper paring cut or in, for thinner cut. If paring knife is skipping or not paring correctly, simply adjust paring knife (Z) by moving very slightly, approximately $\frac{1}{32}$ ".

Core only (Optional Core-Only attachment included with #861. For all other models order Core-Only attachment from Optional Parts List on page 10.)

1. Push paring knife (Z) away from Apple Machine until it locks into position behind retaining bar, then remove slicer/corer (F). Attach corer (T) to mounting plate (M) with bolt. For Model #860, first remove paring knife holder (E) by unscrewing nut and bolt.

MODEL #860:

Pare only

Remove slicer/corer (F), this allows the paring knife to work alone.

Slice and Core only

Remove paring knife holder (E) by unscrewing the nut and bolt.

MODEL #861:

Pare only

Remove slicer/corer (F), this allows the paring knife to work alone.

Core only

Push paring knife (Z) back away from Apple-Mate until it locks into position behind retaining bar. Remove slicer/corer (F), attach corer (T) to mounting plate (M) with bolt.

Slice and Core only

Push paring knife (Z) back away from Apple-Mate until it locks into position behind retaining bar. Attach slicer/corer (F) to mounting plate (M) with bolt.

Pare and Core only

Leave paring knife (Z) in cutting position. Remove slicer/corer (F), attach corer (T) to mounting plate (M) with bolt.

MODEL #864, 865, 866:

Pare only

Remove slicer/corer (F), this allows the paring knife to work alone.

Slice and Core only

Push paring knife holder (E) back, away from Apple Machine until it locks into position behind retaining bar. Leave slicer/corer (F) attached.

MODEL #865, 866 and 866-2

Releasing Vacuum Base:

When releasing suction lever, hold lever firmly and release slowly.

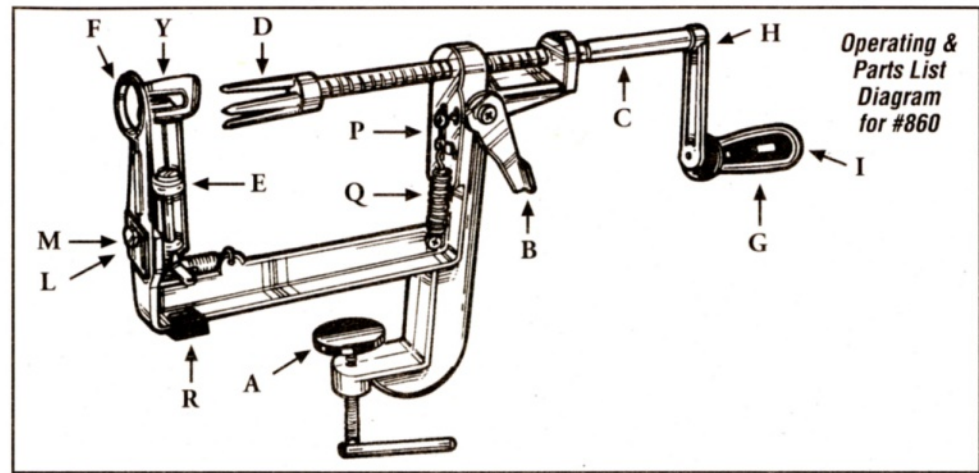

Operating & Parts List Diagram for #860

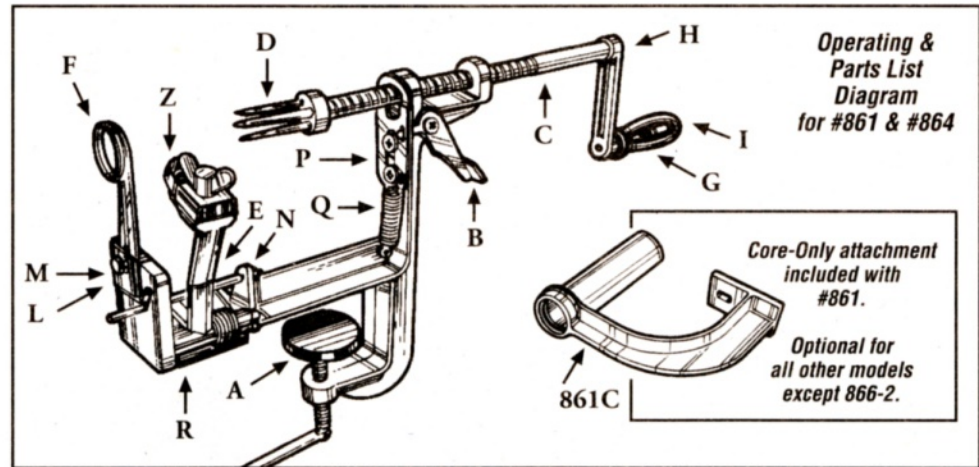

Operating & Parts List Diagram for #861 & #864

Core-Only attachment included with #861.

Optional for all other models except 866-2.

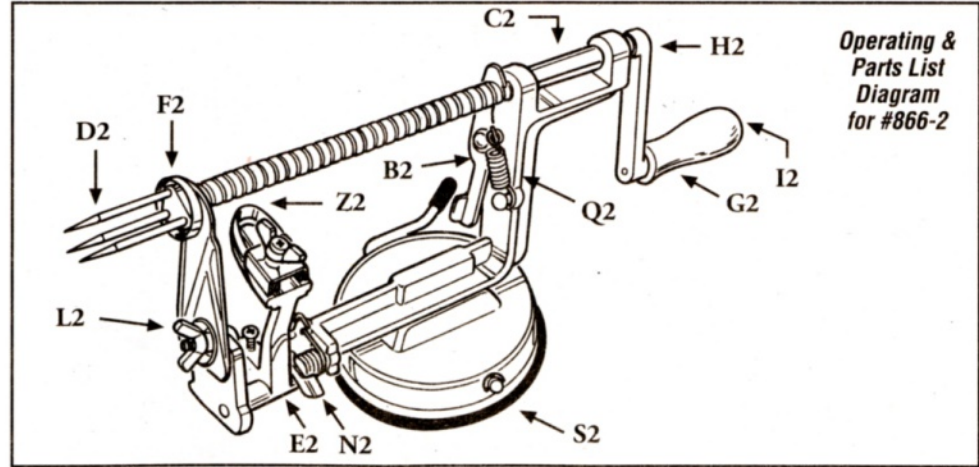

Operating & Parts List Diagram for #866-2

TROUBLESHOOTING

To prevent damage, it is important that your Apple machines be adjusted properly before each use. Refer to the following instructions each time you set up your machine and you will enjoy years of trouble free service.

All Models:

Be sure **Slicer/Corer Blade** is facing the right way. When using the slicer/corer blade, be sure flanged end of blade faces away from 3 pronged fork and support plate is in proper position. (See diagram below).

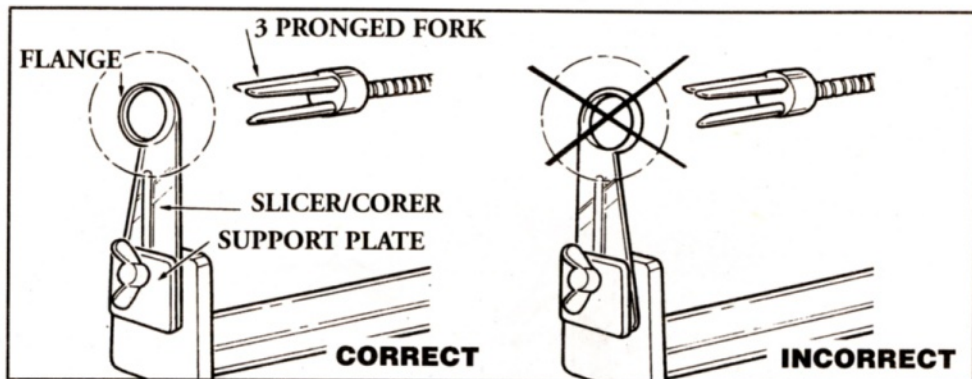

All Models:

Align Corer or Slicer/Corer Blade. Release groove clamp and push shaft all the way in. Align slicer or corer with the 3 prong fork so that there is an even space all the way around the 3 pronged fork. (See diagram at right).

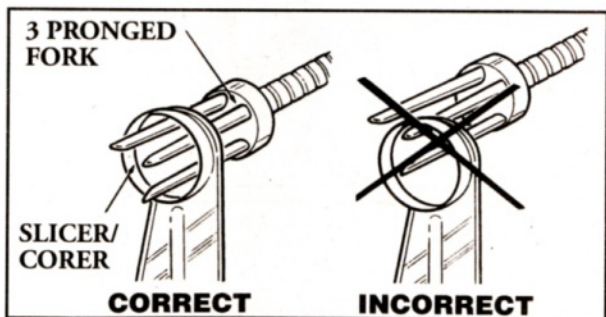

Model #860:

Face Paring Knife Blade the right way. If paring knife blade has been removed for cleaning, be sure it is facing the right way before using. (See diagram at right).

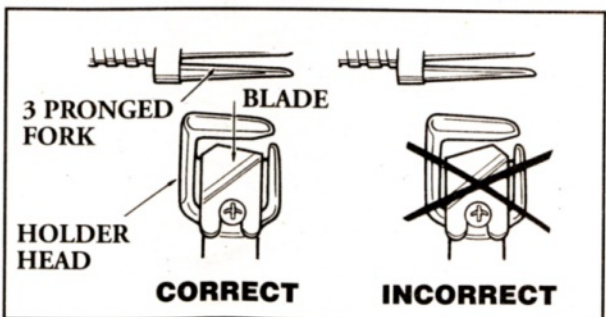

TROUBLESHOOTING

Models #861, 864, 865, 866:

Adjust Paring Knife Blade.

The correct setting should have the peeling blade approximately even with the rounded end of holder. To adjust for proper peeling thickness for different variety of apples, loosen wing nut and move blade forward or back slightly, i.e. 1/32" until you obtain desired peeling depth. Make sure there is an even space between

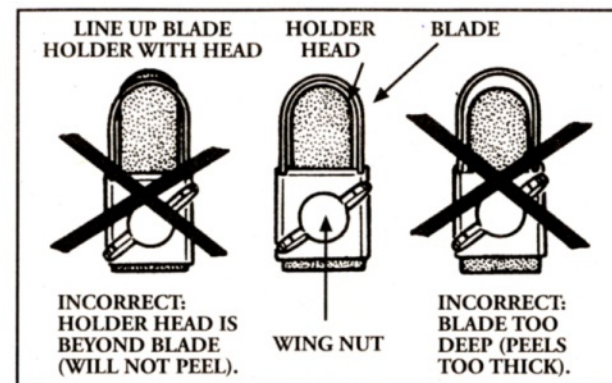

holder head and blade as shown. Hold firmly in desired position and tighten wing nut securely. Note: By moving blade forward (away from holder) more apple will be peeled and by moving blade back less apple will be peeled. (See diagram above-right).

ALL MODELS:

Problem	Cause	Solution
Won't pare properly. Will not peel.	Paring blade needs cleaning. Paring blade not properly adjusted.	Rinse off paring blade. Adjust paring blade.
Parer removes too much fruit with peel.	Paring blade is set too deep.	Adjust paring blade for shallower cut. See diagram above.
Fruit breaks up before being completely sliced.	Fruit is too soft.	Use only fresh, hard fruit.
Part of core is sliced with fruit.	Fruit is not centered on 3 pronged fork.	Be sure fruit is centered on 3 pronged fork.
Won't core properly.	Coring blade not aligned properly.	Align coring blade.
Fruit won't slice.	Slicing blade is on backwards.	Be sure slicing blade is facing right way.

Care Instructions:

Apple juice is very sticky when dry, it is important for satisfactory operation the unit be hand washed and dried thoroughly after every use. If you are processing a large number of apples, it is recommended that you rinse and dry your machine occasionally.