

KitchenAid®

PASTA PRESS

INSTRUCTIONS AND RECIPES

PRESSE-PÂTE

INSTRUCTIONS ET RECETTES

PRENSA PARA PASTA

INSTRUCCIONES Y RECETAS

KPEXTA



This accessory has been approved for use with all KitchenAid® household stand mixers.

L'utilisation de cet accessoire a été approuvée pour tous les batteurs sur socle ménagers de KitchenAid®

Este accesorio se ha aprobado para usarse con todas las batidoras de uso doméstico con base KitchenAid®



W10236413B

FOR THE WAY IT'S MADE.®

U.S.A.: 1-800-541-6390
Canada: 1-800-807-6777

KitchenAid.com
KitchenAid.ca

Proof of Purchase

Always keep a copy of the sales receipt showing the date of purchase of your Stand Mixer Accessory. Proof of purchase will assure you of in-warranty service.

Please complete the following for your personal records:

Model Number _____

Date Purchased _____

Store Name and Location _____

Preuve d'achat

Veillez conserver une copie du coupon de caisse indiquant la date d'achat de votre Accessoires Du Batteur Sur Socle. La preuve d'achat vous assure du service après-vente sous garantie.

Veillez remplir ce qui suit pour votre dossier personnel :

Numéro de modèle _____

Date d'achat _____

Nom du magasin et emplacement _____

Comprobante de compra

Siempre conserve una copia del recibo de ventas que especifique la fecha de compra de sus aditamentos para la batidora con base. El comprobante de compra le asegurará el servicio técnico bajo garantía.

Complete lo siguiente para su registro personal:

Número del modelo _____

Fecha de compra _____

Nombre de la tienda y dirección _____

Table of Contents

INTRODUCTION

Proof of Purchase	Inside Front Cover
Stand Mixer Accessory Safety	2
Important Safeguards	2

FEATURES AND OPERATION

To Assemble Pasta Press Accessory	3
Pasta Plates	5
To Attach Pasta Press Accessory	6
To Use Pasta Press Accessory	6
To Change the Pasta Plates	7
To Loosen the Pasta Ring	7
Care and Cleaning	8
Pasta Making Tips	9
Cooking Pasta	10

RECIPES

Basic Egg Noodle Pasta	10
Light Wheat Pasta	11
Whole Wheat Pasta	11
Spinach Pasta	11
Deluxe Macaroni and Cheese	12
Classic Minestrone	13
Pasta with Roasted Fresh Vegetable Sauce	14
Asparagus, Tomato and Fusilli Salad	15
Bolognese Pasta Sauce	16
Seafood Cream Sauce	17
Rustic Baked Rigatoni	18
Chinese Peanut Noodles	19

WARRANTY AND SERVICE INFORMATION

KitchenAid® Stand Mixer Accessory Warranty	20
Hassle-Free Replacement Warranty – 50 United States and District of Columbia	21
Hassle-Free Replacement Warranty – Canada	21
How to Arrange for Warranty Service in Puerto Rico	21
How to Arrange for Service after the Warranty Expires – All Locations	22
How to Arrange for Service Outside these Locations	22
How to Order Accessories and Replacement Parts	22

Stand Mixer Accessory Safety

Your safety and the safety of others are very important.

We have provided many important safety messages in this manual and on your appliance. Always read and obey all safety messages.



This is the safety alert symbol.

This symbol alerts you to potential hazards that can kill or hurt you and others.

All safety messages will follow the safety alert symbol and either the word "DANGER" or "WARNING." These words mean:

! DANGER

You can be killed or seriously injured if you don't immediately follow instructions.

! WARNING

You can be killed or seriously injured if you don't follow instructions.

All safety messages will tell you what the potential hazard is, tell you how to reduce the chance of injury, and tell you what can happen if the instructions are not followed.

IMPORTANT SAFEGUARDS

When using electrical appliances, basic safety precautions should always be followed including the following:

1. Read all instructions.
2. To avoid risk of electrical shock, do not put mixer in water or other liquid.
3. Close supervision is necessary when any appliance is used by or near children.
4. Unplug the mixer from outlet when not in use, before putting on or taking off parts, and before cleaning.
5. Avoid contacting moving parts. Keep fingers out of feed and discharge openings.
6. Do not feed dough by hand. Always use the combo tool to push food.
7. Do not operate the mixer with a damaged cord or plug or after the mixer malfunctions, or is dropped or damaged in any manner. Return the mixer to the nearest Authorized Service Center for examination, repair or electrical or mechanical adjustment.
8. The use of accessories not recommended or sold by KitchenAid may cause fire, electric shock or injury.
9. Do not use the mixer outdoors.
10. Do not let the cord hang over the edge of table or counter.
11. Do not let cord contact hot surface, including the stove.
12. This product is designed for household use only.
13. Also see Important Safeguards included in the mixer Instructions and Recipes booklet.

SAVE THESE INSTRUCTIONS

To Assemble Pasta Press Accessory

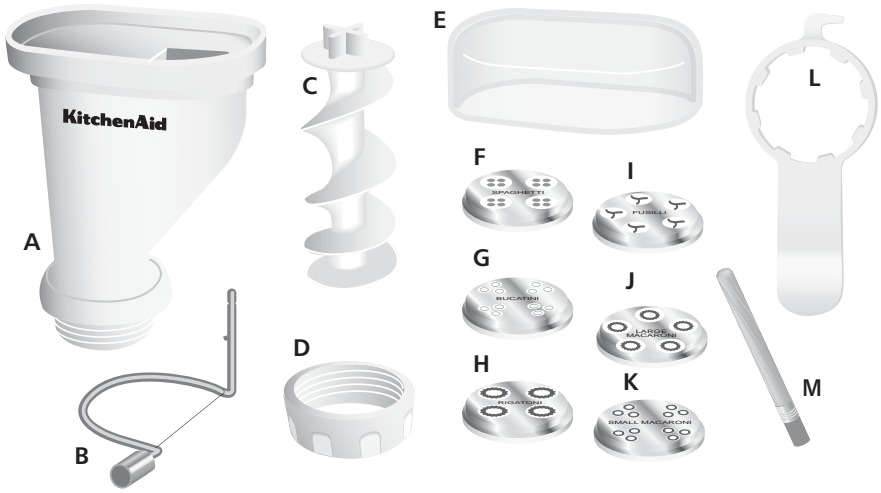

A - Housing
B - Cutter
C - Auger
D - Pasta Ring
E - Storage Case

F - Spaghetti Plate
G - Bucatini Plate
H - Rigatoni Plate
I - Fusilli Plate
J - Large Macaroni Plate

K - Small Macaroni Plate
L - Combo Tool
M - Cleaning Brush

1. Place the press upside down on a counter or table, and insert the end of the auger with the cross-shaped peg (C) into the press housing (A), aligning the cross-shaped peg with the matching indentation inside. When correctly positioned, the top of the auger will be flush with the opening.
2. Place one of the pasta plates (F, G, H, I, J or K) over the opening, aligning its center with the auger, matching the tabs of the plate with the notches in the press housing.

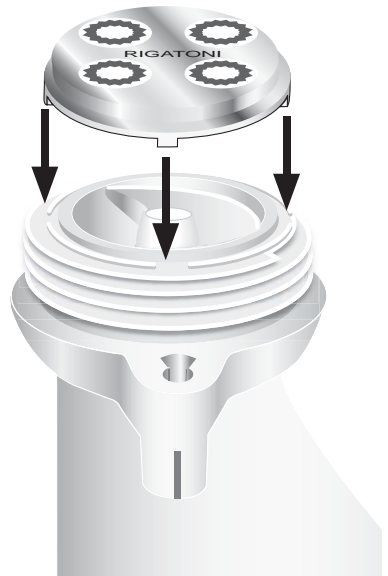
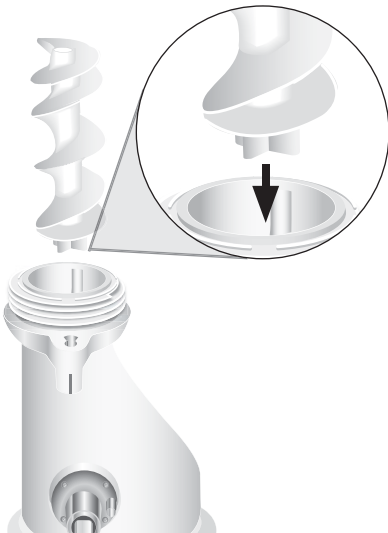

To Assemble Pasta Press Accessory

3. Place the pasta ring (D) over the plate and gently turn by hand until finger tight but not over tightened.



4. Insert the cutter (B) into the socket, aligning the flange with the left side of the slot as shown. Push in until locked in place and turn cutter to the right. The pasta press is now ready to attach to the stand mixer.

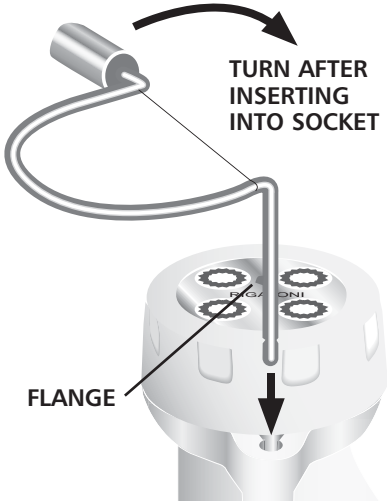

A multipurpose combo tool (L) with a hook and wrench is provided. The flat end may be used to help push dough into the press. The wrench may be used to loosen the pasta ring from the press body. The hook may be used to pry the auger out of the casing.



A storage case (E) is provided to store pasta plates (F, G, H, I, J and K).

NOTE: Do not use combo tool to tighten pasta ring.

Pasta Plates

WARNING

Food Poisoning Hazard

Do not let foods that contain perishable ingredients such as eggs, dairy products, and meats remain unrefrigerated for more than one hour.

Doing so can result in food poisoning or sickness.



SPAGHETTI (PLATE F)

Recommended Stand Mixer Speed: 10

Extrusion Length -
Approximately 9½" (24.0 cm).



BUCATINI (PLATE G)

Recommended Stand Mixer Speed: 10

Extrusion Length -
Approximately 9½" (24.0 cm).



RIGATONI (PLATE H)

Recommended Stand Mixer Speed: 6

Extrusion Length -
Approximately 1½" (4.0 cm).



FUSILLI (PLATE I)

Recommended Stand Mixer Speed: 2-4

Extrusion Length -
Traditional (Long): 9½"
(24.0 cm); Short: 1½"
(4.0 cm).



LARGE MACARONI (PLATE J)

Recommended Stand Mixer Speed: 6

Extrusion Length - Up to 2"
(5.0 cm).



SMALL MACARONI (PLATE K)

Recommended Stand Mixer Speed: 6

Extrusion Length - Up to 1½"
(4.0 cm).

Separating Fresh Pasta

Separate pasta after extrusion. Pasta may be cooked immediately. If drying instead of cooking, place long noodles on KitchenAid® Drying Rack (KPDR), or dry in a single layer on a towel placed on a flat surface. Short pasta should be dried on a flat surface.

Storing Fresh Pasta

To store fresh pasta, air dry for 1 hour, then wrap in an airtight plastic bag and refrigerate for up to 5 days. Long noodles (except fusilli) may be formed into a "nest" before drying.

To Attach Pasta Press Accessory

Before Attaching Pasta Press Accessory

Remove "Do not immerse in water" label, and detach the storage case from the accessory housing top.

To Attach:

1. Turn stand mixer speed control to OFF.
2. Unplug the stand mixer.
3. Loosen the accessory knob (P) by turning it counterclockwise.
4. Remove the accessory hub cover or flip up hub cover.
5. Insert the accessory shaft housing (N) into the accessory hub (O) making certain that accessory power shaft fits into square hub socket.

6. It may be necessary to rotate the accessory back and forth. When the accessory is in proper position, the pin on the accessory housing will fit into the notch on the hub rim.
7. Tighten the accessory knob by turning it clockwise until the accessory is completely secured to stand mixer.

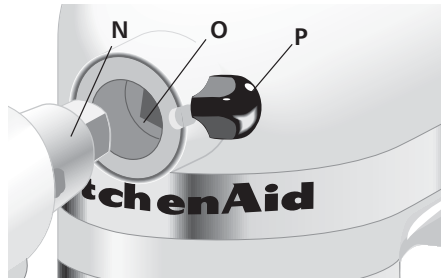

To Use Pasta Press Accessory

⚠ WARNING



Rotating Blade Hazard

Always use food pusher.

Keep fingers out of openings.

Keep away from children.

Failure to do so can result in amputations or cuts.

1. Set the stand mixer speed between 6 and 10, according to pasta type and personal preference. For best results, Fusilli should be extruded at a maximum speed of 6. Slower speeds are also recommended for very short pasta. Longer pasta, such as Spaghetti may be extruded at higher speeds.

2. Slowly feed walnut-size pieces of dough into the hopper; dough should self-feed. The auger should be visible before adding the next piece of dough.



3. Use combo tool to push dough only if dough becomes caught in hopper and no longer self feeds.



To Use Pasta Press Accessory

4. Use the swing-arm wire dough cutter to cut pasta at desired length as it exits the press. See "Pasta Plates" for recommended lengths.

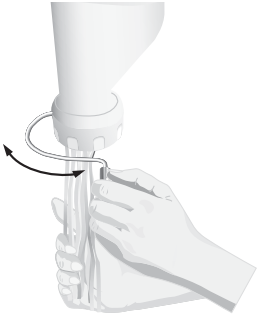

5. Separate pasta as described in "Pasta Plates" section.

To Change the Pasta Plates:

1. Turn stand mixer speed control to OFF.
2. Unplug the stand mixer.
3. Remove the pasta press accessory from the stand mixer.
4. Remove the cutter, pasta ring, auger and clean the dough out of the press housing.
5. Then reassemble the accessory as stated in "To Assemble Pasta Press Accessory" section.

To Loosen the Pasta Ring:

1. If pasta ring is too tight to remove by hand, slip the wrench over the grooves.
2. Turn pasta ring in direction indicated by the arrow to OPEN.



NOTE: Do not use wrench to attach ring to press housing. Damage to the accessory may result.

Care and Cleaning

To Clean:

1. Turn stand mixer speed control to OFF.
2. Unplug the stand mixer.
3. Completely disassemble pasta press.
4. Use the wrench end of combo tool to loosen pasta ring. Use the hook to pry out the auger from press housing.



5. Allow remaining dough on pasta plates to dry overnight before separating. Remove completely dried dough with the Cleaning Brush. Use a wooden skewer or toothpick to pick out any remaining dough. Do not use metal objects or put pasta plates in the dishwasher to clean.
6. Auger, pasta ring, combo tool and storage case are dishwasher safe.

NOTE: Do not wash press housing in dishwasher or immerse in water or other liquids. The cutter and pasta plates should be hand washed in warm sudsy water and dried thoroughly.

NOTE: These accessories are designed to be used with pasta dough only. To avoid damaging your pasta press, do not insert anything other than pasta dough.

Pasta Making Tips

NOTE: Mixer must rest at least 1 hour after extruding 2 consecutive pasta dough recipes.

Dough

- Learning to make homemade pasta is simply a matter of practice. If you have not made pasta, you may have to prepare several batches of dough before you feel comfortable. We recommend experimenting with the Basic Egg Noodle Pasta Recipe.
- The ratio of liquid to flour is small, making the pasta dough firm and leathery, but still pliable. It is extremely important to have the correct proportion of ingredients for proper dough consistency, as dough that is too moist or too dry will be difficult to work with. To help you achieve consistent results, the pasta recipes in this booklet specify sifted flour. To sift flour, follow this procedure: Place dry ingredient measuring cup on a large piece of waxed paper and hold sifter directly above and close to cup. Scoop flour into sifter and sift until flour exceeds top of cup. Using the flat edge of a spatula, remove excess flour from measuring cup.
- Occasionally, there may be unmixed pieces of dough in the bowl after initial mixing with the flat beater. These pieces will be sufficiently incorporated by stand mixer kneading followed by hand kneading which firms and smoothes the texture of the dough.
- Many factors, such as humidity, brand of flour used, and size of eggs, can affect dough consistency. To compensate for humid conditions, start the initial mixing process with only the sifted flour and eggs. Check the dough for proper consistency by pinching a small amount of dough together after mixing with the flat beater. The dough should stay together without sticking to your fingers. It may be necessary to add a small amount of water or flour to reach correct dough consistency.

- If the prepared dough is too moist or sticky to extrude, simply dust with flour or pat some flour into the dough before placing in the extruder.

Using Your Pasta Press and KitchenAid® Stand Mixer

- Long noodles and macaroni tend to curl in different directions as they extrude through the plate. The first 10" (25.0 cm) of curled noodles may be pulled off and returned to the hopper to be extruded again. Pasta will extrude slowly at first, then faster as more dough is extruded.

WARNING

Food Poisoning Hazard

Do not let foods that contain perishable ingredients such as eggs, dairy products, and meats remain unrefrigerated for more than one hour.

Doing so can result in food poisoning or sickness.

- Separate pasta immediately after extrusion. Lay a group of noodles on a towel placed on a flat surface and pull apart from dried ends of strands. Dry in a single layer. Long strands of pasta may be placed on a KitchenAid® Drying Rack (KPDR).
- Homemade pasta behaves differently than store-purchased pasta. Because long noodles bend as they dry and are more fragile, they require gentle handling before cooking.

Storing Your Pasta

- Store dried pasta in an airtight glass or plastic container almost indefinitely in a cool, dark place. However, do not store dried whole-wheat pasta for more than 1 month, as it may turn rancid.
- To store fresh pasta, air dry for 1 hour, then wrap in an airtight plastic bag and refrigerate for up to 5 days. To freeze, double wrap the pasta and keep frozen for up to 4 months. To use frozen fresh pasta, do not thaw – it should go directly from freezer into boiling water.

Cooking Pasta

WARNING

Food Poisoning Hazard

Do not let foods that contain perishable ingredients such as eggs, dairy products, and meats remain unrefrigerated for more than one hour.

Doing so can result in food poisoning or sickness.

ENGLISH

Add 2 tsp (10 mL) salt and 1 tbs (15 mL) oil (optional) to 6 qt (5.7 L) boiling water. Gradually add pasta and continue to cook at a boil until pasta is “al dente” or slightly firm to

the bite. Pasta floats to the top of the water while cooking, so stir occasionally to keep it cooking evenly. Drain in a colander.

- Dry pasta – 7 minutes
- Fresh pasta – 2–5 minutes depending on thickness of noodles

Basic Egg Noodle Pasta

4 *large eggs*
3½ *cups (830 mL) sifted all-purpose flour*
1 *tbs (15 mL) water*
1 *tsp (2 mL) salt*

Break eggs into a glass measuring cup. Check to see that eggs measure $\frac{7}{8}$ cup (207 mL). If less than $\frac{7}{8}$ cup (207 mL), add water, 1 tsp (2 mL) at a time, until measurement is reached.

Place flour and salt in stand mixer bowl. Attach bowl and flat beater. Turn to Speed 2 and gradually add eggs and 1 tbs (15 mL) water. Mix for 30 seconds. Stop mixer and exchange flat beater for dough hook. Turn to Speed 2 and knead for 2 minutes.

Remove mixture from bowl and place on clean surface. Dough may appear crumbly. Hand knead for 30 seconds to 1 minute or until dough is smooth, pliable and holds together in a ball.

Form walnut-sized pieces and extrude pasta into desired shape. Separate and dry as desired, then follow cooking instructions above.

Yield: About 1 ¼ pounds (579 g) dough

Light Wheat Pasta

- 2¹/₂ cups (590 mL) sifted whole wheat flour
 1 cup (235 mL) sifted bread or unbleached flour
 4 large eggs (7/8 cup [208 mL] eggs)
 2 tbs (30 mL) water
 1/2 tsp (2 mL) salt

Place whole wheat flour, bread flour, eggs, water, and salt in stand mixer bowl. Attach bowl and flat beater. Turn to Speed 2 and mix 30 seconds.

Exchange flat beater for dough hook. Turn to Speed 2 and knead 2 minutes. Remove dough from bowl and hand knead for 1 to 2 minutes.

Form walnut-sized pieces of dough and extrude pasta into desired shape. Separate and dry as desired, then follow the "Cooking Pasta" instructions.

Yield: 1¹/₄ lbs (565 g) dough.

Whole Wheat Pasta

- 4 large eggs (7/8 cup [208 mL] eggs)
 2 tbs (30 mL) water
 3¹/₂ cups (830 mL) whole wheat flour
 1/2 tsp (2 mL) salt

Place eggs, water, whole wheat flour, and salt in stand mixer bowl. Attach bowl and flat beater. Turn to Speed 2 and mix 30 seconds.

Exchange flat beater for dough hook. Turn to Speed 2 and knead 2 minutes. Remove dough from bowl and hand knead for 2 minutes.

Form walnut-sized pieces of dough and extrude pasta into desired shape. Separate and dry as desired, then follow the "Cooking Pasta" instructions.

Yield: 1¹/₄ lbs (565 g) dough.

Spinach Pasta

- 1 package 10 oz (285 g) frozen chopped spinach, thawed
 1 tbs (15 mL) water
 4 large eggs (7/8 cup [208 mL] eggs)
 4 cups (945 mL) sifted all-purpose flour

Place spinach in a towel and wring out all water until spinach feels very dry. Finely chop spinach using a food grinder accessory, food processor or blender.

Place chopped spinach, water, eggs, and flour in stand mixer bowl. Attach bowl and flat beater. Turn to Speed 2 and mix 30 seconds.

Exchange flat beater for dough hook. Turn to Speed 2 and knead 2 minutes. Remove dough from bowl and hand knead for 1 to 2 minutes.

Form walnut-sized pieces of dough and extrude pasta into desired shape. Separate and dry as desired, then follow the "Cooking Pasta" instructions.

Yield: 1¹/₂ lbs (680 g) dough.

Deluxe Macaroni and Cheese

- 3 tbs (45 mL) butter
- 2 tbs (30 mL) finely minced onion
- 2 tbs (30 mL) flour
- 3 cups (780 mL) milk
- 4 oz (120 mL) extra sharp Cheddar cheese, shredded
- 4 oz (120 mL) Fontina cheese, shredded
- 1 tsp (5 mL) Worcestershire sauce
- 1/4 tsp (1 mL) garlic salt
- 1/8 tsp (0.5 mL) pepper
- 1/8 tsp (0.5 mL) paprika
- 1 recipe basic egg noodle pasta extruded into short-cut large macaroni, cooked and drained

Melt butter in a large saucepan over medium heat. Add onion and cook, stirring occasionally, for 4 to 5 minutes or until translucent. Add flour and cook an additional minute. Whisk in milk, and continue cooking over medium heat until mixture comes to a boil and thickens slightly. Reduce to low heat and stir in Cheddar and Fontina cheeses, mixing until melted and well incorporated. Add Worcestershire sauce, garlic salt, pepper, and paprika, stirring well to combine. Remove from heat and set aside.

Place cheese mixture and cooked macaroni in large bowl, mixing well to combine. Transfer mixture to a greased 9" x 13" x 2" (23 cm x 33 cm x 5 cm) baking pan. Cover tightly with foil and bake at 350°F (180°C) for 25 to 30 minutes. Remove foil and bake an additional 10 minutes to brown and crisp top. Serve immediately.

Yield: 10 servings.

Per Serving: About 214 cal., 11 g protein, 16 g carb, 12 g total fat, 56 mg cholesterol, 258 mg sodium.

Classic Minestrone

- 3 tbs (45 mL) olive oil
- 2 stalks celery, trimmed and cut into 1/4" (0.65 cm) slices
- 3 carrots, peeled and cut into 1/4" (0.65 cm) slices
- 2 small zucchini, trimmed and cut into 1/4" (0.65 cm) slices
- 1 small onion, chopped
- 1 shallot, finely chopped
- 1 package (32 oz) (946 mL) chicken broth
- 2 cans (14.5 oz [429 mL] each) petite diced tomatoes with juice
- 1 tsp (5 mL) dried oregano
- 1 tsp (5 mL) dried basil
- 1/4 tsp (1 mL) pepper
- 1/2 recipe basic egg noodle pasta extruded into short-cut small macaroni, uncooked
- 1 can (15.8 oz [467 mL]) white beans, rinsed and drained

Heat olive oil in large pot over medium high heat. Add celery, carrots, zucchini, onion, and shallot. Cook and stir for 4 to 5 minutes, or until vegetables are softened.

Add chicken broth, tomatoes, oregano, basil, and pepper. Increase heat to high and bring mixture to a boil. Add pasta, and continue to boil until pasta has reached al dente stage, about 4 to 5 minutes. Reduce heat to low and stir in beans. Simmer an additional 5 minutes or until beans are heated through. Serve immediately.

Yield: 10 servings.

Per Serving: About 97 cal., 4 g protein, 16 g carb, 2 g fat, 9 mg cholesterol, 466 mg sodium.

Pasta with Roasted Fresh Vegetable Sauce

- 4 tbs (60 mL) olive oil, divided
- 1 small zucchini, trimmed and cut into $\frac{1}{4}$ " (0.65 cm) slices
- 1 small yellow squash, trimmed and cut into $\frac{1}{4}$ " (0.65 cm) slices
- 1 small onion, chopped
- 3 cloves garlic, minced
- 1 package (8 oz) (235 mL) sliced button or baby Bella mushrooms
- 8 large ripe Roma tomatoes, peeled and seeded if desired, and cut into $\frac{1}{2}$ " (1.25 cm) slices
- 1 tsp (5 mL) salt
- $\frac{1}{8}$ tsp (0.5 mL) pepper
- $\frac{1}{2}$ cup (120 mL) chicken or vegetable broth (if desired)
- $\frac{1}{2}$ recipe basic egg noodle pasta extruded into short-cut large macaroni, cooked and drained
- 2 tbs (30 mL) coarsely chopped basil leaves
- 2 tbs (30 mL) coarsely chopped flat leaf Italian parsley
- $\frac{1}{2}$ cup (235 mL) Parmesan cheese

Coat bottom and sides of a large glass or ceramic baking pan with 1 tbs (15 mL) olive oil. Place zucchini, yellow squash, onion, garlic, mushrooms, tomatoes, salt, and pepper in baking pan. Drizzle with remaining oil and mix well. Bake at 425°F (220°C) for 1 hour, stirring mixture every 20 minutes, until vegetables are tender and caramelized.

Remove from oven and add broth, if desired, to loosen browned bits from bottom of pan and add additional moisture. Let stand 10 minutes. Add hot cooked pasta, basil, parsley, and Parmesan cheese. Mix well to combine and serve immediately.

Yield: 8 servings.

Per Serving: About 149 cal., 6 g protein, 12 g carb, 9 g fat, 17 mg cholesterol, 476 mg sodium.

Asparagus, Tomato and Fusilli Salad

- 1 lb (455 g) asparagus, trimmed and cut into 1" (2.5 cm) pieces
- 1 medium yellow bell pepper, seeded and diced
- 1 package (1 pint) (550 mL) grape tomatoes, halved
- 2 green onions, trimmed and thinly sliced
- 4 ounces (120 mL) smoked provolone cheese, diced
- 1/4 cup (60 mL) chopped parsley
- 1/2 cup (120 mL) olive oil
- 2 tbs (30 mL) balsamic vinegar
- 3 tbs (45 mL) red wine vinegar
- 2 cloves garlic, finely minced
- 1/2 tsp (2 mL) salt
- 1/8 tsp (0.5 mL) pepper
- 1/2 recipe basic egg noodle pasta extruded into short-cut fusilli, cooked, rinsed and cooled

Bring medium saucepan with 2 cups (475 ml) water to boil over high heat. Add asparagus, cover, and continue to boil for 2 to 3 minutes, or until tender crisp. Remove asparagus from pan and immediately submerge in cold water. Rinse well and place in large bowl. Add yellow pepper, tomatoes, green onions, provolone cheese, and parsley. Mix well and set aside.

In small bowl, whisk together oil, vinegars, garlic, salt, and pepper. Pour mixture over vegetables and let stand 15 minutes. Add cooked pasta and mix well to combine.

Cover and refrigerate one hour or until well chilled. Serve cold.

Yield: 8 servings.

Per Serving: About 226 cal., 6 g protein, 11 g carb, 18 g fat, 21 mg cholesterol, 297 mg sodium.

Bolognese Pasta Sauce

*Serve with Spaghetti
or Bucatini Pasta*

- 1 lb (455 g) lean ground beef
- 1 lb (455 g) ground pork
- 2 carrots, peeled and finely chopped
- 2 stalks celery, finely chopped
- 1 medium onion, finely chopped
- 4 cloves garlic, minced
- 1/2 cup (120 mL) dry red wine
- 2 cans (28 oz [828 mL] each) crushed tomatoes
- 2 cans (6 oz [177 mL] each) tomato paste
- 1 can (14 1/2 oz [428 mL]) chicken or beef broth
- 2 tsp (10 mL) dried basil
- 2 tsp (10 mL) dried oregano
- 2 fresh bay leaves
- 1/2 tsp (2 mL) crushed red pepper flakes
- 2 tsp (10 mL) sugar
- Salt and pepper to taste

In large pot or Dutch oven over medium-high heat, cook and crumble ground beef and pork, about 5 minutes. Add carrots, celery, onion, and garlic to pot and continue to cook and finely crumble mixture until meat is thoroughly cooked, about 8 to 9 minutes. Remove from heat and drain all excess fat. Return pot to medium heat and add red wine. Cook and stir 3 minutes. Add remaining ingredients, reduce heat and simmer for 1 hour, stirring occasionally. Remove bay leaves and serve over hot pasta.

Yield: 10 servings.

Per Serving: About 268 cal., 21 g protein, 22 g carb, 11 g fat, 57 mg cholesterol, 820 mg sodium.

Seafood Cream Sauce

*Serve with Large
Macaroni or Fusilli
Pasta*

*8 oz (235 mL) shrimp,
peeled and deveined*

*8 oz (235 mL) bay
scallops*

2 tbs (30 mL) butter

*1 small shallot, finely
chopped*

*1/4 cup (60 mL) dry white
wine*

*1 cup (235 mL) half
and half*

*1 cup (235 mL) grated
Parmesan cheese*

1/4 tsp (1 mL) salt

*1/8 tsp (0.5 mL) pepper
Dash nutmeg*

Place shrimp and scallops between layers of paper towels to remove excess moisture; set aside. Melt butter in large skillet over medium heat. Add shallot and sauté for 2 to 3 minutes, stirring occasionally. Add shrimp and scallops to skillet and cook, stirring occasionally, for 3 to 4 minutes, or just until seafood turns opaque. Stir in white wine and simmer mixture 1 to 2 minutes. Add half and half, Parmesan cheese, salt, pepper, and nutmeg. Continue to cook, stirring occasionally, until mixture just begins to simmer and cheese is melted. Do not boil. Sauce will be thin. Remove from heat immediately and toss with hot pasta.

Yield: 6 servings.

Per Serving: About 248 cal., 22 g protein, 5 g carb,
14 g fat, 109 mg cholesterol, 608 mg sodium.

Rustic Baked Rigatoni

- 1 *tbs (15 mL) olive oil*
- 2 *boneless skinless chicken breasts, sliced into 1/4" (0.65 cm) pieces*
- 2 *Italian sausage links, sliced diagonally into 1/4" (0.65 cm) pieces*
- 1 *small onion, sliced*
- 1 *small green pepper, seeded and sliced*
- 2 *large cloves garlic, minced*
- 1 *tsp (5 mL) chopped fresh rosemary*
- 1/8 *tsp (0.5 mL) cayenne pepper*
- 1 *can (14.5 oz [428 mL]) petite diced tomatoes with juice*
- 3/4 *cup (175 mL) half and half*
- 1/2 *recipe basic egg noodle pasta extruded into short-cut rigatoni, cooked and drained*
- 1/2 *cup (120 mL) shredded Mozzarella cheese*
- 1/4 *cup (60 mL) grated Romano cheese*

Heat oil in large skillet over medium heat. Add chicken and sausage links and cook, stirring occasionally, for 5 to 6 minutes. Add onion, green pepper, and garlic. Continue cooking and stirring until meat is completely cooked through and vegetables are tender, about 6 to 7 minutes. Add rosemary, cayenne pepper, and tomatoes. Stir well to combine and bring mixture to a simmer. Stir in half and half and remove mixture from heat. Add cooked pasta and stir well to combine. Transfer mixture to a greased 2 1/2 -qt (2.3 L) baking dish. Sprinkle with mozzarella and Romano cheeses. Bake at 350°F (180°C) for 15 to 20 minutes, or until heated through. Serve immediately.

Yield: 8 servings.

Per Serving: About 369 cal., 24 g protein, 15 g carb, 24 g fat, 94 mg cholesterol, 587 mg sodium.

Chinese Peanut Noodles

- 1 cup (235 mL) natural peanut butter
- 4 tbs (60 mL) olive oil
- 6 tbs (90 mL) fresh lime juice
- ²/₃ cup (160 mL) light soy sauce
- 2 tsp (30 mL) sugar
- 2 cloves garlic, finely minced
- ¹/₄ tsp (1 mL) cayenne pepper
- ¹/₄ tsp (1 mL) cumin
- 1 recipe basic egg noodle pasta extruded into spaghetti, cooked, drained and cooled
- 1¹/₂ cups (355 mL) fine julienne carrot strips
- 3 green onions, trimmed and thinly sliced
- 3 tbs (45 mL) chopped fresh parsley

Combine peanut butter, olive oil, lime juice, soy sauce, sugar, garlic, cayenne pepper, and cumin in small bowl. Whisk together until smooth. Set aside for 15 minutes to blend flavors.

Place pasta, carrots, green onions, and parsley in large bowl. Pour reserved sauce over mixture and toss to combine. Cover and refrigerate one hour or until well chilled. Serve cold.

Yield: 10 servings.

Per Serving: About 272 cal., 9 g protein, 19 g carb, 19 g fat, 19 mg cholesterol, 818 mg sodium.

KitchenAid® Stand Mixer Accessory Warranty

ENGLISH

Length of Warranty:	KitchenAid Will Pay For:	KitchenAid Will Not Pay For:
<p>50 United States, the District of Columbia, Canada, and Puerto Rico: One-year limited warranty from date of purchase.</p>	<p>50 United States, the District of Columbia and Canada: Hassle-free replacement of your pasta press accessory. See the following page for details on how to arrange for replacement. OR In Puerto Rico: The replacement parts and repair labor costs to correct defects in materials and workmanship. Service must be provided by an Authorized KitchenAid Service Center. To arrange for service, see the following pages.</p>	<p>A. Repairs when pasta press accessory is used in other than normal single family home use. B. Damage resulting from accident, alteration, misuse or abuse or use with products not approved by KitchenAid. C. Replacement parts or repair labor costs for pasta press accessory when operated outside the country of purchase.</p>

DISCLAIMER OF IMPLIED WARRANTIES; LIMITATION OF REMEDIES IMPLIED WARRANTIES, INCLUDING TO THE EXTENT APPLICABLE WARRANTIES OF MERCHANTABILITY OR FITNESS FOR A PARTICULAR PURPOSE, ARE EXCLUDED TO THE EXTENT LEGALLY PERMISSIBLE. ANY IMPLIED WARRANTIES THAT MAY BE IMPOSED BY LAW ARE LIMITED TO ONE YEAR, OR THE SHORTEST PERIOD ALLOWED BY LAW. SOME STATES AND PROVINCES DO NOT ALLOW LIMITATIONS OR EXCLUSIONS ON HOW LONG AN IMPLIED WARRANTY OF MERCHANTABILITY OR FITNESS LASTS, SO THE ABOVE LIMITATIONS OR EXCLUSIONS MAY NOT APPLY TO YOU.

IF THIS PRODUCT FAILS TO WORK AS WARRANTED, CUSTOMER'S SOLE AND EXCLUSIVE REMEDY SHALL BE REPAIR OR REPLACEMENT ACCORDING TO THE TERMS OF THIS LIMITED WARRANTY. KITCHENAID AND KITCHENAID CANADA DO NOT ASSUME ANY RESPONSIBILITY FOR INCIDENTAL OR CONSEQUENTIAL DAMAGES. This warranty gives you specific legal rights and you may also have other rights which vary from state to state or province to province.

Hassle-Free Replacement Warranty – 50 United States and District of Columbia

We're so confident the quality of our products meets the exacting standards of KitchenAid that, if your pasta press accessory should fail within the first year of ownership, KitchenAid will arrange to deliver an identical or comparable replacement to your door free of charge and arrange to have your original pasta press accessory returned to us. Your replacement unit will also be covered by our one year limited warranty. Please follow these instructions to receive this quality service.

If your pasta press accessory should fail within the first year of ownership, simply call our toll-free Customer Satisfaction Center at 1-800-541-6390 Monday through Friday, 8 a.m. to 8 p.m. (Eastern Time), or Saturday, 10 a.m. to 5 p.m. Give the consultant your complete shipping address. (No P.O. Box numbers, please.)

When you receive your replacement pasta press accessory, use the carton and packing materials to pack up your original pasta press accessory. In the carton, include your name and address on a sheet of paper along with a copy of the proof of purchase (register receipt, credit card slip, etc.).

Hassle-Free Replacement Warranty – Canada

We're so confident the quality of our products meets the exacting standards of the KitchenAid brand that, if your pasta press accessory should fail within the first year of ownership, KitchenAid Canada will replace your pasta press accessory with an identical or comparable replacement. Your replacement unit will also be covered by our one year limited warranty. Please follow these instructions to receive this quality service.

If your pasta press accessory should fail within the first year of ownership, take the pasta press accessory or ship collect to an Authorized KitchenAid Canada Service Centre. In the carton include your name and complete shipping address along with a copy of the proof of purchase (register receipt, credit card slip, etc.). Your replacement pasta press accessory will be returned prepaid and insured. If you are unable to obtain satisfactory service in this manner call our toll-free Customer eXperience Centre at 1-800-807-6777. Or write to us at:

Customer eXperience Centre
KitchenAid Canada
1901 Minnesota Court
Mississauga, ON L5N 3A7

How To Arrange for Warranty Service in Puerto Rico

Your pasta press accessory is covered by a one-year limited warranty from the date of purchase. KitchenAid will pay for replacement parts and labor costs to correct defects in materials and workmanship. Service must be provided by an Authorized KitchenAid Service Center.

Take the pasta press accessory or ship prepaid and insured to an Authorized KitchenAid Service Center. Your repaired pasta press accessory will be returned prepaid and insured. If you are unable to obtain satisfactory service in this manner, call toll-free 1-800-541-6390 to learn the location of a Service Center near you.

How To Arrange for Service after the Warranty Expires – All Locations

For service information in the 50 United States, District of Columbia, and Puerto Rico, call toll-free **1-800-541-6390**.

Or write to:
Customer Satisfaction Center
KitchenAid Portable Appliances
P.O. Box 218
St. Joseph, MI 49085-0218

Or contact an Authorized Service Center near you.

For service information in Canada, call toll-free **1-800-807-6777**.

Or write to:
Customer eXperience Centre
KitchenAid Canada
1901 Minnesota Court
Mississauga, ON L5N 3A7

ENGLISH

How To Arrange for Service Outside these Locations

Consult your local KitchenAid dealer or the store where you purchased the pasta press accessory for information on how to obtain service.

For service information in Mexico, call toll-free **01-800-024-17-17** (JV Distribuciones)

Or

01-800-902-31-00
(Industrias Birtman)

How To Order Accessories and Replacement Parts

To order accessories or replacement parts for your pasta press accessory in the 50 United States, District of Columbia, and Puerto Rico, call toll-free **1-800-541-6390** Monday through Friday, 8 a.m. to 8 p.m. (Eastern Time), or Saturday, 10 a.m. to 5 p.m.

Or write to:
Customer Satisfaction Center
KitchenAid Portable Appliances
P.O. Box 218
St. Joseph, MI 49085-0218

To order accessories or replacement parts for your pasta press accessory in Canada, call toll-free **1-800-807-6777**.

Or write to:
Customer eXperience Centre
KitchenAid Canada
1901 Minnesota Court
Mississauga, ON L5N 3A7

To order accessories or replacement parts for your pasta press accessory in Mexico, call toll-free **01-800-024-17-17** (JV Distribuciones)

Or

01-800-902-31-00
(Industrias Birtman)

® Registered trademark/Marque déposée/Marca registrada de KitchenAid, U.S.A.

™ Trademark/Marque de commerce/Marca de comercio de KitchenAid, U.S.A.

KitchenAid Canada licensee in Canada/Emploi sous licence par KitchenAid Canada au Canada/
Usada en Canadá bajo licencia de KitchenAid Canada.

© 2009. All rights reserved. Tous droits réservés. Todos los derechos reservados.



BIEN PENSÉ. BIEN FABRIQUÉ.®