



# USER'S INSTRUCTIONS FOR BUTTER CHURN Reference BAR01

Please read these instructions before using in order to have an efficient and save functioning.



***DO NOT LEAVE A CHILD USE THE APPLIANCE ALONE.  
CONTAINER IN GLASS TO BE HANDLE WITH CARE.  
WASH THE APPLIANCE BEFORE FIRST USE.***

## ASSEMBLING

Screw the handle.

## USE

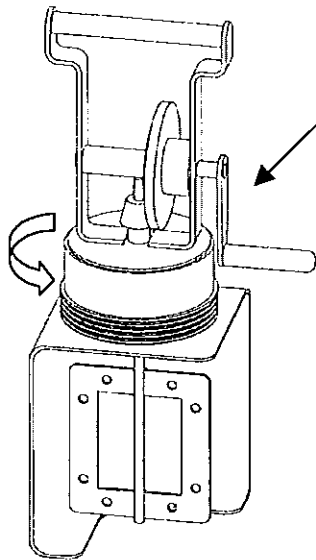

1) Unscrew mechanical system of the appliance.

2) Full the container with cream (see attached recipe).

3) Close the container by screwing the system. Don't grip to much

4) Turn the handle (see attached recipe).

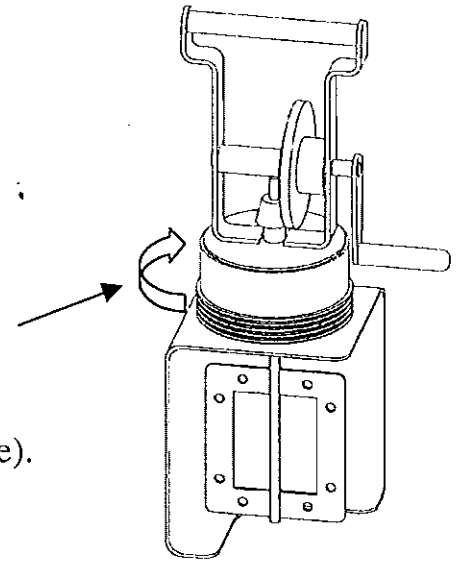

## CLEANING

Clean the appliance under warm water with washing up liquid after each use. The container can be cleaned in a dishwasher.

## MAKE YOUR OWN BUTTER

The butter made is simple if you follow carefully the different steps

### BASIS PRINCIPLES

- The butter is mainly obtained from milk cream.
- The cream must be churned.
- The churning consists of agglomerate the little cells of fat in the cream with a mechanical movement : we obtain butter and whey (or buttermilk).
- Butter is made of water (about 16%), fat content (about 82%) and non fat content (about 2%).
- In salted butter, the salt content is higher than 3%. In slightly salted butter, the content of salt is between 0,5 and 3%.

### MAKE YOUR CREAM ( CREAMING )

It exists different ways to obtain cream from unpasteurized milk (to filter before) or whole milk.

- in heating the milk and recovering the cream thanks to a skimmer.
- in boiling the milk then letting it rest in a cold place (minimum 12 hours); the cream resurfaces and can be retrieved thanks to a skimmer.
- In letting it rest in cold place 24 to 48 hours for the cream to resurface; then it can be retrieved with a skimmer

Note : more important the surface is, more cream is recovered.  
The cream must rest in a cold place 24hours before churning.

20 to 22 liters of milk are necessary to obtain 1kg of butter.

That is why, we advice you to buy cream (as creme fraiche).

To make your butter, use :

- Ideally a liquid cream without emulsifying agent nor stabilising one (possibly with a label), or unpasteurized cream
- a liquid cream
- a single cream
- a double cream

Be careful, the fat content should be at 30% minimum

Depends on the fat content in the used cream, you will get a butter of 130 to 180g for 50cl of cream.

## **THE CHURNING**

To succeed in churning, the cream have to be at a temperature between 10° et 14°.

Bring it in out of the cold 2 hours before and leave it at room temperature.

One of the condition to succeed in churning.

Whatever the cream, use a minimum quantity of 50cl and maximum 80cl.

- pour the cream in the container in glass and close it in screwing the mechanical system (see user's instruction). Do not grip too much.
- turn the handle in a regular way (but no hurried) to thicken the cream (see on the surface)
- as a matter of fact, progressively it will be harder and harder to turn the handle
- slow down : the churning is almost finished.
- when the mechanical system has become hard to turn or slip, the churning is finished.

The churning lasts 3 or 8 minutes according the quantity of cream and the temperature

Recover the butter in pouring out the contents of the container in glass in a colander (don't keep the whey ).

## **WASHING**

Now, you must wash the butter to separate it from the rest of the whey. The period and the quality of preserving depend on a correct washing.

Use a fresh and clear water to wash the butter.

To wash butter :

- put the colander under cold water (don't cream the butter)
- when the rinsing water becomes clear, the washing is finished

## **THE CREAMING**

The creaming will allow the butter to eliminate the rest of whey and homogenise the butter.

Once washed, put the butter in a hollow receptacle, preferably in wood and previously humidified with fresh water ( see the accessories range-ref. BAR140 or BAR141).

Then cream the butter thanks to a spatula, preferably a spoon in wood or a wood half paddle also humidified (see accessories range).

Remark: during the creaming you can salt the butter or aromatize it.  
To salt, use a pure, white and dry salt.  
The salt will preserve the butter (despite the taste)

## **MOULDING**

You can shape the butter, with your hand, and give the form wished. However, different butter moulds exist (preferably in wood –see accessories range) :you will create aesthetic forms and sign your work.

In case you use wood butter moulds, you should previously wet them with cold water.

Place the butter moulded or shaped in a cold place

## **CONSUMPTION - PRESERVING**

The butter put in a cold place after shaping , is ready to be eaten.  
Just turn out it and pack it (in butter paper) as it is more healthy.

The butter can be kept at a temperature between 5 to 6°.  
(Caution, the butter absorbs easily and quickly the smell. You should keep it away from smelling food to preserve the taste .

Can be froze at -18°

## **HYGIENE**

Work with clean hands and respect the hygiene rules.

Wash the material with warm water and a dish-washing liquid.