

# NOMENCLATURE SPARE PARTS

## VEGETABLE SLICER "ROUET GOURMET" REF.4100CLR

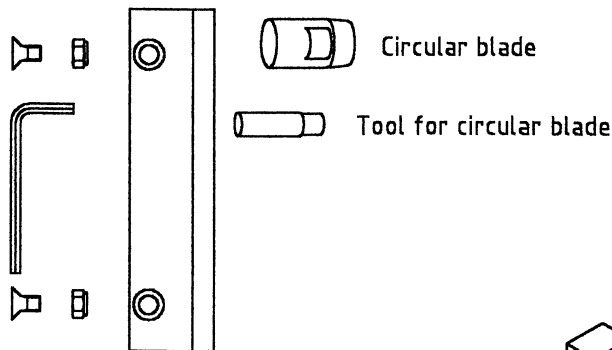

Réf.4046: Spare blades kit (large blade + circular blade + screws + tools)

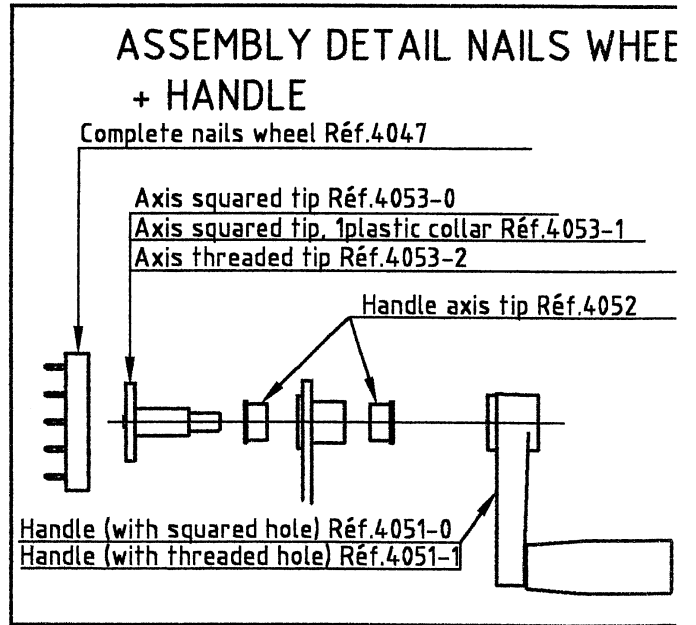
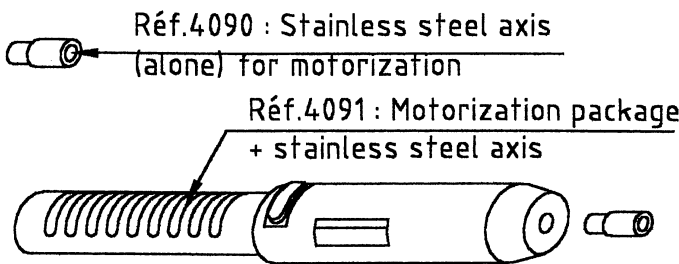
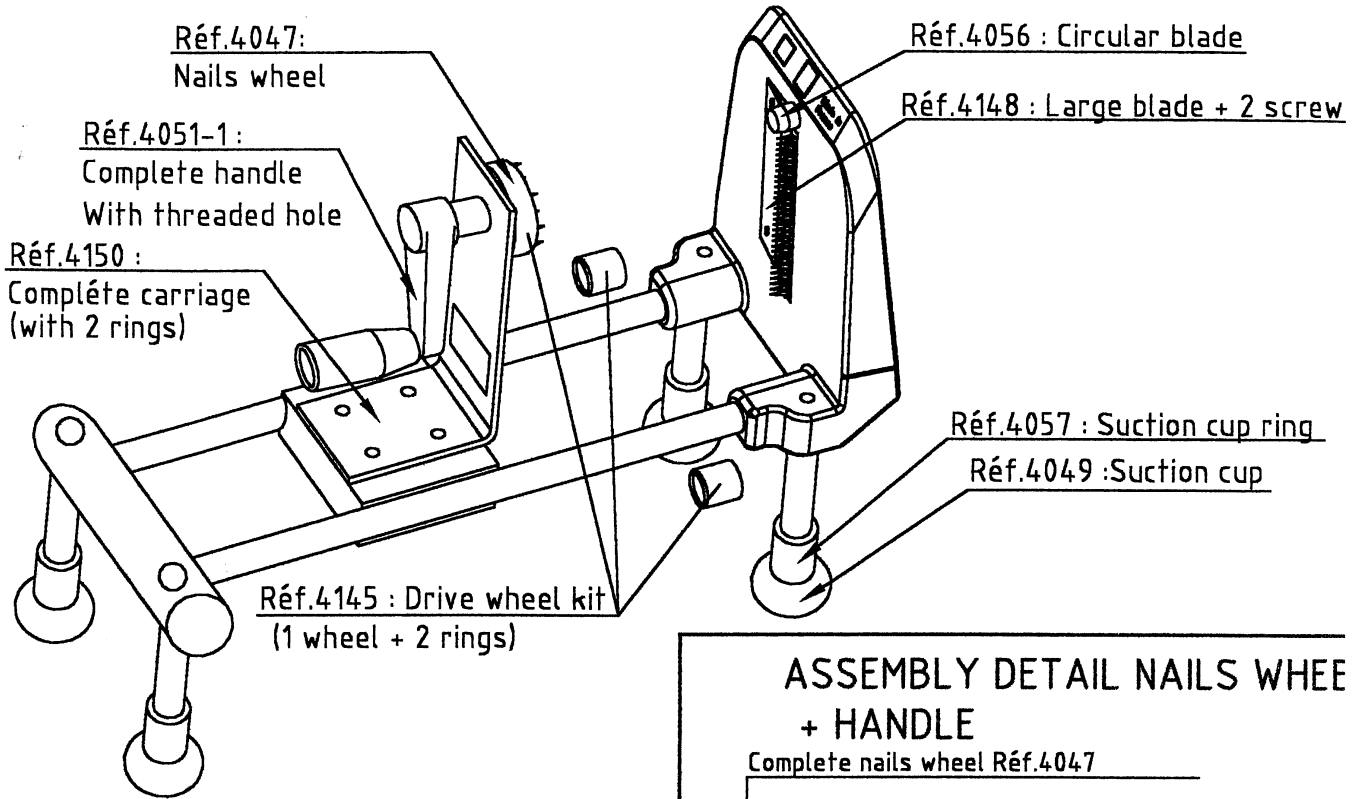